

Sigma I/O Module

Highly interchangeable. Highly configurable.

The Sigma I/O Module is designed to work with the Sigma 3.1 and Sigma 5.1 tool change systems in a variety of applications – from spot welding and mold changing to pick-and-place operations.

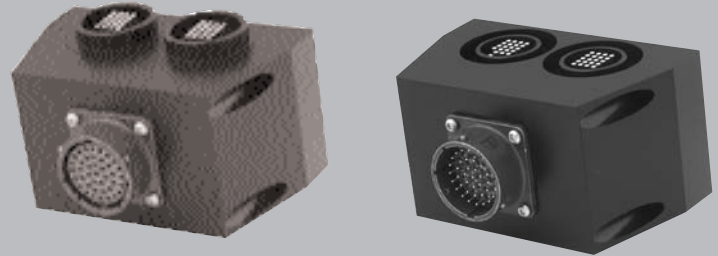

Features and Benefits

- Flexible I/O module system supports different signal requirements
- Available with strain relief, connectors and pre-wired, ready-to-couple signal
- Modules are interchangeable between the Sigma 3.1 and Sigma 5.1 modules

Not exactly what your application requires? Applied Robotics can design a solution that meets your particular application needs.

SPECIFICATIONS

Robot Module weight	0.94 kg / 2.1 lb
Tool Machine weight	0.84 kg / 1.9 lb
Current/Probe	5 amps
Resistance/Probe	50 (mOhm)
Wire Gauge for Receptacles	22 - 26 AWG

EXTERNAL ELECTRICAL MODULE

Order #	Description	Spring Force (lbf)	No. Probes		Mating Connector
			Total	User I/O	
S-EM-R-E-32.05-MS	XChange Electrical Module, Robot	25	40	32	KPT08F22-36S
S-EM-T-E-32.05-MS	XChange Electrical Module, Tool	25	40	32	KPT08F22-36P
S-EM-R-E-13.05-MS	XChange Electrical Module, Robot	12.5	20	13	MS3108B22-14S
S-EM-T-E-13.05-MS	XChange Electrical Module, Tool	12.5	20	13	MS3108B22-14P
S-EM-R-E-27.05-MS-VD*	XChange Electrical Module, Robot	25	40	29	KPT08F22-36S
S-EM-T-E-27.05-MS-VD*	XChange Electrical Module, Tool	25	40	29	KPT08F22-36P

* need for use with valve module

Note: Specifications provided are maximum recommended limits under static conditions. For correct product sizing, consideration must be given to all dynamic forces, including manipulator inertia, tooling configuration and external process forces.

Note: For correct product sizing, please contact our Tech Support staff at techsupport@arobotics.com or at (800)309-3475 or (518)384-1000.

Engineering Data

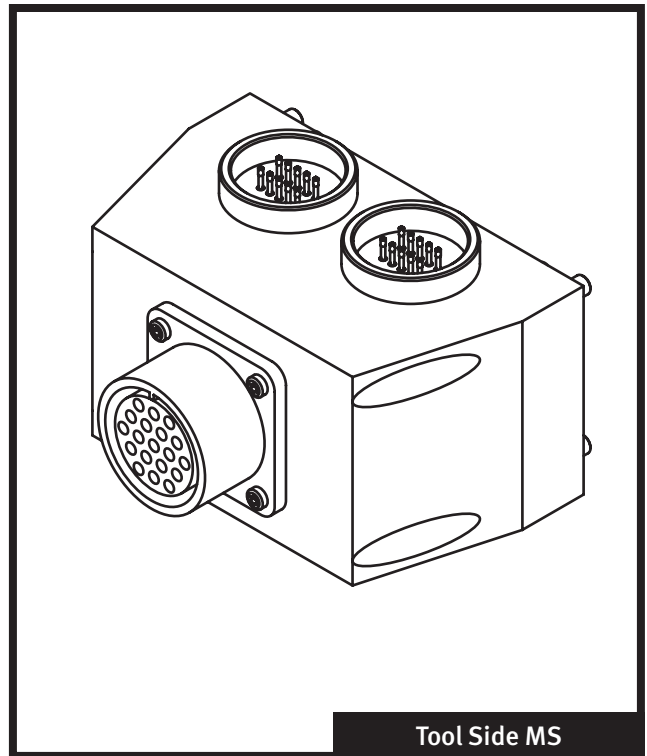
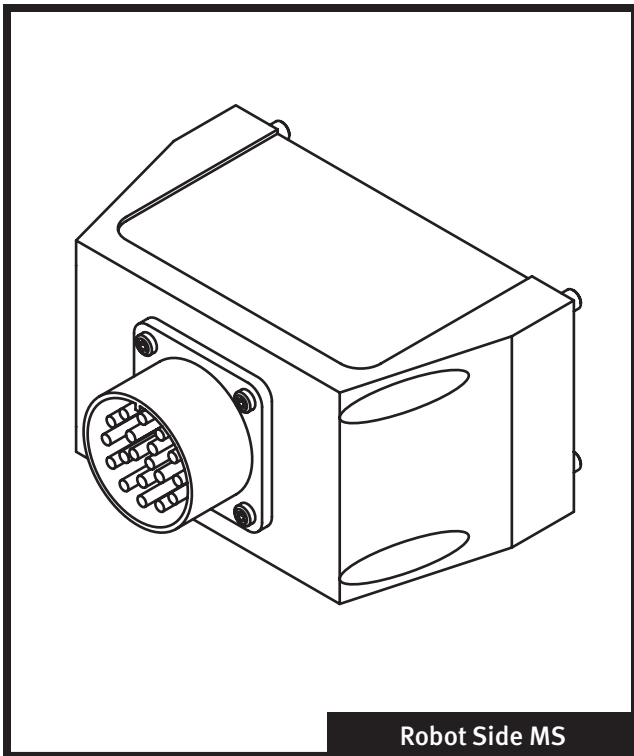
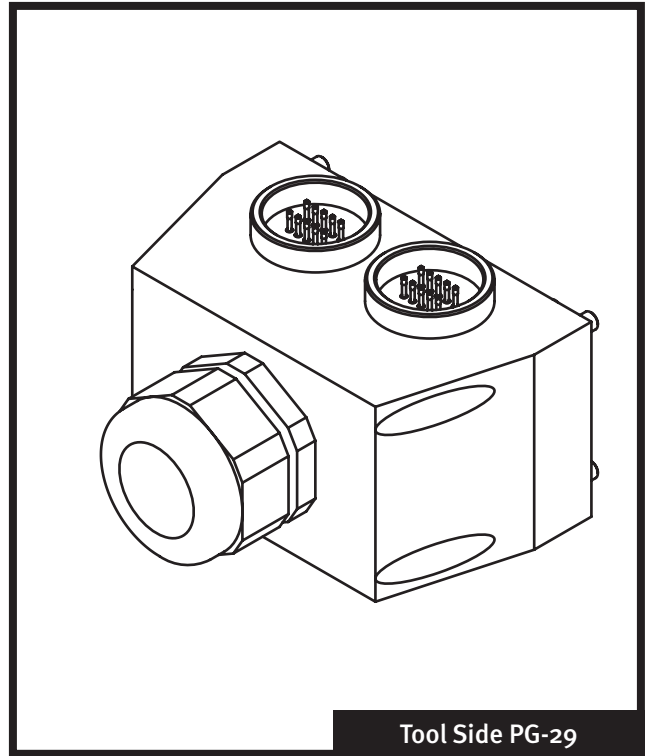
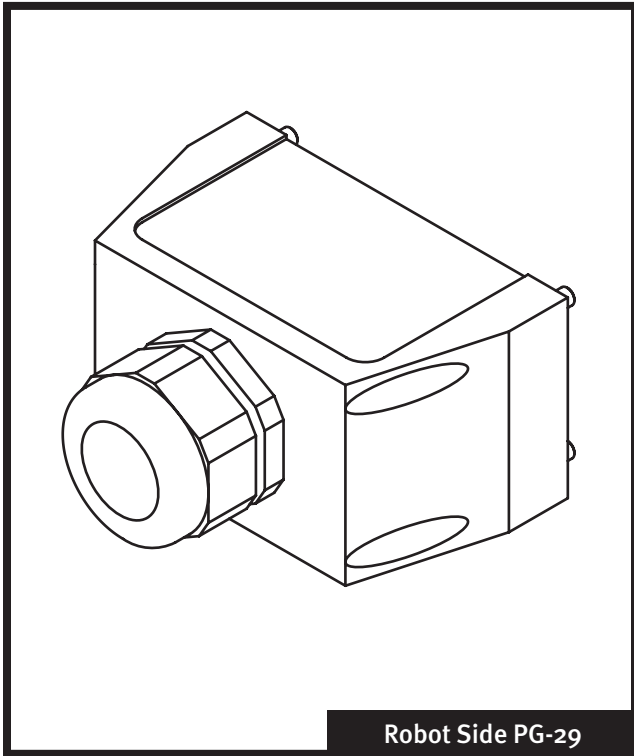

648 Saratoga Road
Glenville, NY 12302 USA
518 384 1000 tel
518 384 1200 fax

29193 Northwestern Hwy. #509
Southfield, MI 48034 USA
248 358 3677 tel
248 358 2654 fax

www.arobotics.com



Sigma Modules

With onboard optional pneumatic, electrical, and coolant modules mounted directly to the Sigma 3.1 or Sigma 5.1, the Sigma Modules offer the flexibility to disconnect any utility requirement.

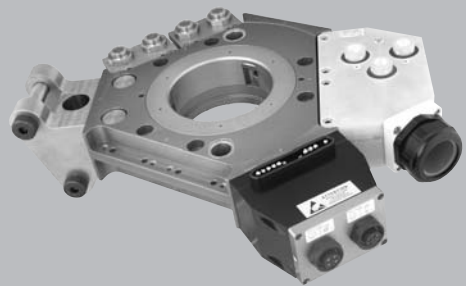

Features and Benefits

- All modules are interchangeable between the Sigma 3.1 and 5.1, reducing spare parts investment and installation time.

Not exactly what your application requires? Applied Robotics can design a solution that meets your particular application needs.

Note: Specifications provided are maximum recommended limits under static conditions. For correct product sizing, consideration must be given to all dynamic forces, including manipulator inertia, tooling configuration and external process forces.

Note: For correct product sizing, please contact our Tech Support staff at techsupport@arobotics.com or at (800)309-3475 or (518)384-1000.

Applications

- Spot welding (Pneumatic/Servo)
- Material handling
- Machine loading/unloading
- Mold changing
- Docking systems
- Pallet coupling systems
- Pick and place operations
- Press transfer

Engineering Data

VALVE MODULE



Description	Weight	Cv	Max Response time	Operating Pressure	Power Voltage (VDC)	Consumption (WDC)
External Valve Module Two Position, Double Solenoid, Latching	0.57 kg/ 1.26 lb	0.9	24 ms	6 bar +/- 1 87 psi +/- 15	24	1

Overall dimensions: 126.0mm x 57.0mm x 43.0mm (4.96" x 2.24" x 1.69")
Control cable included

continued

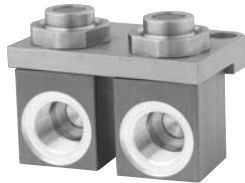

PNEUMATIC MODULE

Description	Weight	Fitting size	Cv
Pneumatic Module	0.36 / .8 lb	3/4 NPT / BSPP	1.54
Pneumatic Module	0.36 / .8 lb	3/4 NPT / BSPP	1.54

Overall dimensions: 76.0mm x 51.75mm x 50.0mm (2.99" x 2.04" x 1.97")
 Special version includes fittings and hose to supply valve

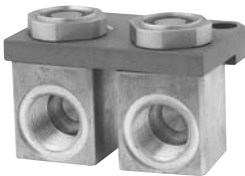

COOLANT MODULE

Description	Weight	Fitting size	Cv
Brass External Coolant Module	0.36 / .8 lb	3/4 NPT / BSPP	1.54
Brass External Coolant Module	0.36 / .8 lb	3/4 NPT / BSPP	1.54

Overall dimensions: 76.0mm x 51.75mm x 50.0mm (2.99" x 2.04" x 1.97")
 Special version includes fittings and hose to supply valve



HKVA MODULE

Description	Number of Contacts	Weight	Amperage Rating	Voltage Rating
Robot	3	1.4 kg / 3.08 lb	200	600
Tooling	3	1.5 kg / 3.3 lb	continuous	